

## Application for a New Connection

FOR OFFICIAL USE ONLY

B.P. No: \_\_\_\_\_  
MPRN: \_\_\_\_\_

## Introduction

This application form outlines the information ESB Networks DAC requires to progress an application for connection to the Electricity Distribution System. All applications must comply with the Distribution Code and ESB Networks DAC Conditions Governing Connection to the Distribution System. These can be found on our website: [esbnetworks.ie](http://esbnetworks.ie).

Please note that this application form only deals with LV (230/400V), 10kV, 20kV, 38kV and in some cases, 110kV connections. If a higher connection voltage is required the applicant should contact the Customer Relations Team in EirGrid: +353 1 237 0472 or [info@eirgrid.com](mailto:info@eirgrid.com).

ESB Networks DAC reserves the right to request additional data if necessary and the applicant should provide such information promptly during and post the offer process.

It is ESB Networks DAC responsibility to determine distribution connection method. If the applicant has a specific request this will be considered and examined in this process. The selected method will be based on the overall least cost technically acceptable solution **unless the Applicant requests otherwise or ESB Networks DAC requires an alternative method for system reasons.**

This application form must be submitted in both **paper and electronic format**. Electronic files must be submitted on CD or via email (all electronic files should be a cumulative maximum of 5MB or less).

Definitions of terms used in this form can be found in the glossary of the Distribution Code.

When the application form is fully completed please send the form and all relevant documentation to:

**Generator Applications**  
**ESB Networks DAC**  
**Leopardstown Road**  
**Foxrock**  
**Dublin 18**  
**D18 XN80**

If any queries arise ESB Networks DAC can be contacted at 1850 372 757 or [DSOgenerators@esb.ie](mailto:DSOgenerators@esb.ie)

Please note that in accordance with the Commission of Regulation of Utilities, some information from your completed application form will be published on the ESB Networks website: [esbnetworks.ie](http://esbnetworks.ie). Please also see CRU's website for more detail: [cru.ie](http://cru.ie).

Please Note: Information contained within this application form may need to be shared with the Transmission System Operator in order to sufficiently assess your application.

The Form NC5 should be used where an applicant has identified their specific generator manufacturer detail and would like their technical study processed using the specified data provided by the applicant. Form NC5A is a shortened version of this form and may be used where the specific generator manufacturer detail is unknown at time of application. Therefore the technical study is completed using assumed data and the applicant is required to provide their specific data a year in advance of energisation. For more detail on which is the most suitable, please refer to our website [esbnetworks.ie](http://esbnetworks.ie)

**Please note: Incomplete applications will be returned.**



Please fill in ALL sections in BLOCK CAPITALS

PART 1 - ALL APPLICANTS

1. APPLICANT DETAILS:

Full name of the applicant: (if a company or a partnership give full company or trading name) Full address of legal applicant required

[Grid for name entry]

Full address of legal applicant required (in the case of a body corporate, the registered or principal office)

[Grid for address entry]

Company registration number required [Grid]

Telephone Number: [Grid]

Email: [Grid]

Contact details as per above. Company's registered address will be used as the contact address.

Contact Person: [Grid]

2. SITE DETAILS:

Project Name: (Please note the Project Name must be geographically reflective of the location of the generator and must not match any existing generator name or substation. The Project Name will be published on [esbnetworks.ie](http://esbnetworks.ie))

[Grid for Project Name entry]

Site Name & Address:

[Grid for Site Name & Address entry]

Site Substation Co-ordinates of Connection Point:

EASTINGS: [Grid]      NORTHINGS: [Grid]

(For a project with the Maximum Export Capacity greater than 0.2 MW the connection point will be at the customer's substation site. For all other projects please use the co-ordinates of the generator unit itself. The co-ordinates to be supplied are the Irish Grid Co-ordinates, e.g. E243,566 N050,334)

3. GENERAL DETAILS:

Projected Start-Up Date: (month and year)

[Grid for Start-Up Date entry]

Target Connection Date: (month and year)

[Grid for Connection Date entry]

This Project is applying to export energy      Yes  No

If Yes - MEC. If No - What is the required Embedded Generation

[Grid for Embedded Generation entry]

Generation Maximum Export Capacity (MEC) Required (MW): (if extension then only the additional capacity)

(For generators which operate in parallel with the network and do not require a MEC, please include 0 MWs here and ensure to include the associated MPRN below.)

[Grid for MEC entry]

This project is an extension to an existing installation (MPRN) Yes  No

This project is an extension to a planned generator      Yes  No

If 'yes' please provide the existing project name and the Meter Point Reference Number (MPRN):

[Grid for MPRN entry]

#### 4. GENERATOR APPLICATION FEES

Please note that a deposit of €7,000 (incl VAT) which is part of the application fee or the full application fee if the total application fee amount is less (both non-refundable) must accompany the application. Please visit our website [esbnetworks.ie](http://esbnetworks.ie) for more information. Details can be found in Generator Connections Section. Please refer to our website [esbnetworks.ie](http://esbnetworks.ie) on payment methods available. Please use your Project Name as the reference if paying by electronic fund transfer (EFT).

**Applications submitted without this fee will be returned.**

Noted \*  Date of EFT Payment

#### 5. MAPS AND DIAGRAMS: Please provide both paper and electronic copies of the following:

A 1:50,000 "Discovery Series" Ordnance Survey map, with the location of the facility clearly marked with an "X" and indicating the site boundary.

A plan of the site (in an appropriate scale) of the proposed facility, indicating the site boundary, the proposed location of the connection point, generators, transformers, site buildings etc.

A draft electrical single line diagram of the proposed facility detailing all significant items of plant and their values including:

- Relevant Voltage Levels
- Interlocking
- Earthing and Synchronising Arrangements
- Relay Types
- CT/VT ratios
- Generator Transformer(s)
- Power Factor Correction
- Location of Alternative Connections (e.g. house load)
- Network Connecting Transformer(s) (if applicable)

**Please note: we will not be able to process your application without these maps/diagrams**

#### 6. SITE LOAD DATA:

Maximum Import Capacity Required (kVA):

#### 7. TECHNICAL DETAILS: Unit and Plant capability data

Number of Generation Units (for solar projects this is the number of solar invertors):

**For thermal plant only:** please provide a functional block diagram of the main plant components, showing boilers, turbines, heat recovery boilers, alternators, any heat or steam supplies to other processes etc. indicating e.g. whether single shaft or separate shaft

Please note: we will not be able to process your application without this.

	Unit 1 (or Type 1)	Unit 2 (or Type 2)	Unit 3 (or Type 3)
Type of Generation Plant: <small>[combined cycle combustion turbine, steam turbine, wind generator, etc]</small>			
If two or more technology types are to be constructed under this MEC, please state what portion of the MEC (as set out in General Details Section) is attributed to each type of generation plant:			
Make/Version of Generator:			
Type of Generator: <small>[synchronous, asynchronous, converter connected, etc.]</small>			
Number of generators of type:			
Normal Maximum Continuous Generation Capacity (MW):			
Normal Maximum Continuous Export Capacity (MW):			
Maximum (Peaking) Generating Capacity (MW):			
Maximum (Peaking) Export Capacity (MW):			
Minimum Continuous Generating Capacity (MW):			
Minimum Continuous Export Capacity (MW):			
Generator Rated MVA:			
Normal Minimum Lagging Power Factor:			
Normal Minimum Leading Power Factor: <small>(Power Factor capabilities will be in accordance with The Distribution Code)</small>			
Generator Voltage (kV):			
Please provide details of the expected running regime: <small>(i.e. continuous/peak lopping/peak shaving)</small>			

Please provide a [calculation sheet](#) (in addition to the fault current figures requested in Table 1) showing the fault current available (r.m.s. value of the a.c. symmetrical component) from the Embedded Generation Facility due to a fault at the Connection Point when all generating sets are operating in parallel with the Electricity Distribution System.

7. TECHNICAL DETAILS: Cont'd (This section must be completed in full. A reference to another document is not acceptable and will be deemed incomplete.)

Short Circuit Current Contribution from Embedded Generation Facility IEG [kA] [RMS]	Fault types applied at Connection Point		
	Three-Phase	Phase-to-Phase	Single-Line to-Ground (*)
t = 0.00s			
t = 0.02s			
t = 0.04s			
t = 0.06s			
t = 0.08s			
t = 0.10s			
t = 0.12s			
t = 0.14s			
t = 0.16s			
t = 0.18s			
t = 0.20s			
t = 0.30s			
t = 0.40s			
t = 0.60s			
t = 0.90s			
t = 1.30s			
t = 1.70s			
t = 2.00s			
t = 3.00s			

(\*) Not necessary for connections at 10kV or 38kV.

Table 1

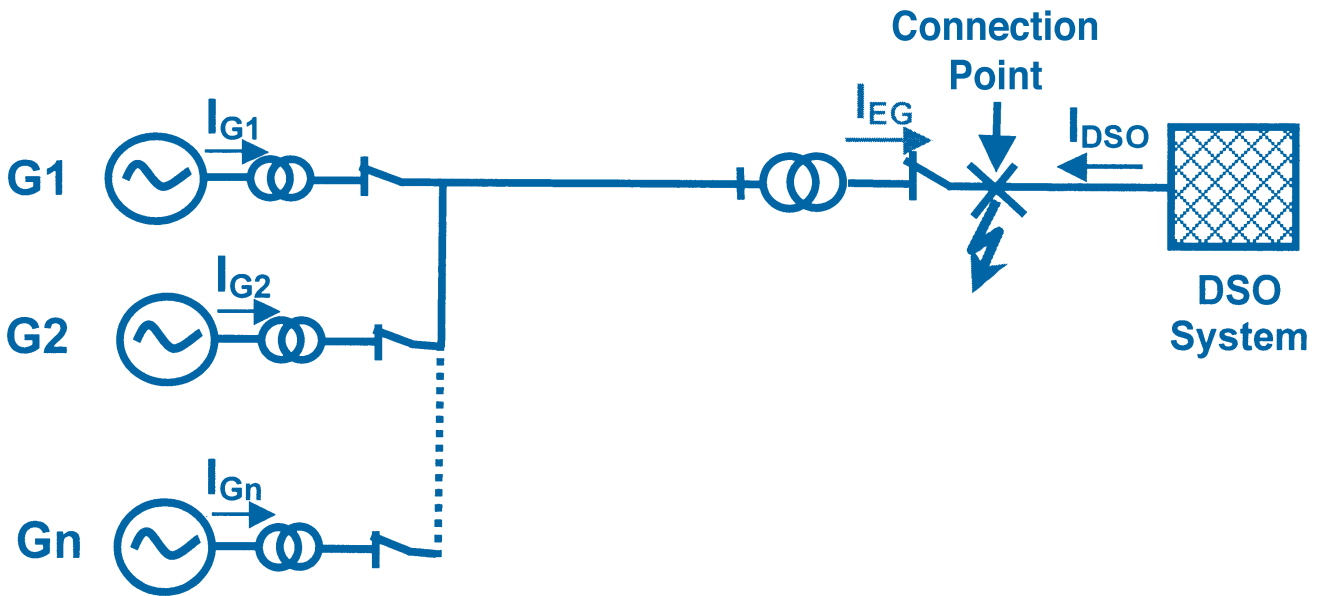

Legend:

**EG:** Fault Current Contribution from Embedded Generation Facility

**IDSO:** Fault Current Contribution from DSO System

**IGn:** Fault Current Contribution from Individual Generation Unit

Figure 1 Embedded Generation Facility and Fault Current Contributions

## 8. NETWORK CONNECTION TRANSFORMER DATA (if applicable):

There are many types of transformers. This application specifies two winding transformers. All impedances should be stated in % on transformer rated MVA and kV.

Please note that the connection voltage is determined by ESB Networks DAC in accordance with normal standards, as outlined in the Distribution Code, taking into account the particulars of each application. If the connection voltage is different to that assumed in the application, ESB Networks DAC will request new data corresponding to the new voltage level and the process will stand suspended until such reasonable data is obtained.

Please note that a full manufacturers test report may be required at a later stage. Noted

State number of transformers proposed at the network connection point  
(at the connection voltage level i.e. not transformers associated with individual generators): \_\_\_\_\_

Transformer Rated MVA: \_\_\_\_\_

Transformer Voltage Ratio HV/LV [kV]: \_\_\_\_\_

Transformer Winding Configuration: \_\_\_\_\_

Transformer positive sequence resistance (R1%): \_\_\_\_\_

Transformer positive sequence reactance (X1%): \_\_\_\_\_

Transformer zero sequence resistance (R0%): \_\_\_\_\_

Transformer zero sequence reactance (X0%): \_\_\_\_\_

Please provide details of Tap Changer. Nature of tap changer (off load/on load/ off circuit)

\_\_\_\_\_

Tapped Voltage Winding: \_\_\_\_\_ kV + \_\_\_\_\_ Steps - \_\_\_\_\_ Steps \_\_\_\_\_ % Step Size

## 9. GENERATOR TRANSFORMER DATA (i.e. transformers associated with individual generators):

	Unit 1 (or Type 1)	Unit 2 (or Type 2)	Unit 3 (or Type 3)
Generator Transformer Rated MVA:			
Generator Transformer Voltage Ratio HV/LV kV:			
Generator Transformer Winding Configuration:			
Generator Transformer positive sequence resistance (R <sub>1</sub> %)			
Generator Transformer positive sequence reactance (X <sub>1</sub> %)			
Generator Transformer zero sequence resistance (R <sub>0</sub> %)			
Generator Transformer zero sequence reactance (X <sub>0</sub> %)			
Please provide details of Tap Changer. Nature of tap changer (off load/on load/ off circuit)			
_____			
Tapped Voltage Winding: _____ kV + _____ Steps - _____ Steps _____ % Step Size			

## 10. POWER QUALITY

Please note that questions regarding power quality will be included with the Connection Agreement and MUST be completed at that stage for the Connection Agreement to be valid.

Noted

## 11. INDEPENDENCE OF CONTIGUOUS GENERATORS:

A Generator Power Station will be deemed to be unrelated to and independent of the other generator Power Stations already present in a Contiguous Generator Site ("Independent generator Power Station") if:

- the Applicant, where a body corporate, is not a related undertaking of another Generator Power Station already present in the Contiguous Generator Site or in respect of which an application for a Connection Agreement has been made to the DSO or the TSO;
- no person or body corporate holding 50% or more of the equity or voting rights in the Applicant is a person connected with any other person or body corporate holding 50% or more of the equity or voting rights in another Generator Power Station present in the Contiguous Generator Site ("Connected Person").

The Generator Power Station is/will be independent from contiguous Generators Yes  No



### 15. GENERATOR DATA FOR FAULT STUDIES (Short Circuit)

Please provide the below specified currents or submit a short circuit current decrement curve (current vs time) representing your generators:	Unit 1 (or Type 1)	Unit 2 (or Type 2)	Unit 3 (or Type 3)
$I_k''$ - Initial symmetrical short circuit current			
$I_p$ - Peak short circuit current			
$I_k$ - Steady state short circuit current			

### PART 4 - NON-SYNCHRONOUS GENERATORS WITH AN MEC LESS THAN OR EQUAL TO 5MW

#### 16. NON-SYNCHRONOUS GENERATORS:

State the Generator type:

(fixed speed stall regulated; fixed speed pitch regulated; fixed speed pitch regulated with variable rotor resistance; variable speed with doublyfed induction generator; variable speed with synchronous generator and fully-rated converter or other specified type)

Unit 1 (or Type 1)	
Unit 2 (or Type 2)	
Unit 3 (or Type 3)	

Please attach the approved power curve

Please note: we will not be able to process your application without this

#### 17. DYNAMIC SIMULATION DATA:

In the connection offer process the dynamic impact of the generator on the transmission and distribution systems is examined. To be able to carry out dynamic simulation the applicant needs to submit the electrical data in questions below.

If the requirements in questions below are being met by the provision of a dynamic model, then the applicant does not need to answer questions below. All necessary parameters and data must accompany the model. The dynamic model should be available from the manufacturer and should be suitable for software program PSS/E and specific to the type of generator unit to be installed.

Further, if the appropriate model has already been provided to EirGrid by the manufacturer then the same model does not need to be provided again as long as the applicant explicitly advises the following for the model in question:

The version number of the model

The sender (i.e. name & company) of the model:

The (EirGrid) recipient of the model

Specify by what method the model was sent (e.g. email, CD etc):

The date the model was sent to EirGrid

The remaining questions in part 4 are only to be filled in if the applicant is not submitting a dynamic model







## 20. DYNAMIC SIMULATION DATA:

In the connection offer process the dynamic impact of the generator on the transmission and distribution systems is examined. To be able to carry out dynamic simulation the applicant needs to submit a dynamic model of their generator. This dynamic model should be available from the manufacturer.

Please submit a dynamic model and all data and parameter values required for the dynamic model. The dynamic model should be suitable for software program PSS/E and specific to the type of generator unit to be installed. This should be submitted in electronic version.

**Please note: we will not be able to process your application without this.** However, if the appropriate model has already been provided to EirGrid by the manufacturer then the same model does not need to be provided again as long as the applicant explicitly advises the following for the model in question:

The version number of the model

The sender (i.e. name & company) of the model:

The (EirGrid) recipient of the model

Specify by what method the model was sent (e.g. email, CD etc):

The date the model was sent to EirGrid

Please submit a written statement, preferably from your manufacturer, detailing confirmation of commitment to "meaningful engagement" to progress the level of modelling to an appropriate validated model. "Meaningful engagement" shall be interpreted as:

- a. commitment on the part of the applicant to deal with and respond to issues raised by EirGrid with regard to the generator and generator modelling in a timely manner and
- b. the applicant providing details of a specific contact(s) to deal with issues and queries relating to the performance and modelling of the generator, the overall performance and modelling of the generator and the operation of the PSS/E dynamic model.

**Please note: we will not be able to process your application without this.**

## PART 6 - DS3 APPLICANTS ONLY

### 21. DS3 PRIORITISATION TECHNICAL DETAILS REQUIRED<sup>1</sup>:

Please indicate which services can be provided

FFR  POR

#### Fast Frequency Response

What level of FFR can be provided? \_\_\_\_\_ (MW)

For how many hours per year can the service be provided? \_\_\_\_\_ Hrs

#### Service at low MW outputs

Can the service be provided at 0MW output levels? Yes  No

Can the service be provided while operating below 20% of MEC? Yes  No

#### Primary Operating Reserve

What level of POR can be provided? \_\_\_\_\_ (MW)

For how many hours per year can the service be provided? \_\_\_\_\_ Hrs

#### Service at low MW outputs

Can the service be provided at 0MW output levels? Yes  No

Can the service be provided while operating below 20% of MEC? Yes  No

<sup>1</sup>Applicants that are successfully included in a batch through DS3 prioritisation must deliver the service(s) as stated. If an applicant makes a false, misleading or inaccurate declaration in respect of DS3 eligibility requirements, this will be deemed to be an "event of default" under any resulting connection agreement. Applications that are included in a batch on the basis of DS3 prioritisation cannot subsequently change to an alternative technology

PART 7 - ALL APPLICANTS

22. PLANNING PERMISSION CONFIRMATION<sup>1</sup>: (This section applies to all applicants<sup>2</sup>)

Telephone: \_\_\_\_\_ Email: \_\_\_\_\_

I, (Name in Block Capitals): \_\_\_\_\_

Position: \_\_\_\_\_

on Behalf of (Company Name in Block Capitals as specified in Applicant Details of this application form)

\_\_\_\_\_

confirm that Planning Permission for the generator units as specified in this application form (including the size, orientation, number and output of generation units)' is in place as follows:

Planning Reference No: \_\_\_\_\_

Planning Permission Grant Date: \_\_\_\_/\_\_\_\_/\_\_\_\_ Planning Permission Expiry Date: \_\_\_\_/\_\_\_\_/\_\_\_\_

Extension applied for? Yes  No

**OR**

Confirm that Planning Permission for the generator unit(s) as specified in this application is not required for the following reason:

\_\_\_\_\_

\_\_\_\_\_

\_\_\_\_\_

Signed: \_\_\_\_\_ Date: \_\_\_\_\_

I, (Name in Block Capitals): \_\_\_\_\_

Profession: \_\_\_\_\_

on Behalf of (Company Name in Block Capitals as specified in Applicant Details of this application form)

Signed: \_\_\_\_\_ Date: \_\_\_\_\_

warrant that I have conducted the necessary checks and am satisfied that the aforementioned planning permission is in place.

Solicitors/ Planning Consultant Address  
\_\_\_\_\_

Solicitors<sup>3</sup>/ Planning Consultant Number<sup>4</sup>  
\_\_\_\_\_

Solicitor / Planning Consultant Stamp (where possible):

<sup>1</sup> As per CRU/18/059 if an applicant makes a false, misleading or inaccurate declaration in respect of planning permission requirements, this will be deemed to be an "event of default" under the connection agreement.  
<sup>2</sup> As per CRU/18/058 applicants seeking DS3 prioritisation are not required to have planning permission for the purpose of entering into the 2018 batch however it is strongly advised as planning permission is one of the prioritisation criteria in the event of over-subscription as per CRU/18/060.  
<sup>3</sup> As per the Law Society of Ireland (www.lawsociety.ie)  
<sup>4</sup> As per the Irish Planning Institute (www.ipi.ie) or Royal Town Planning Institute (www.rtpiconsultants.co.uk)

### 23. LANDOWNER CONSENT CONFIRMATION:

Mobile number:  Landline:

I, (Name in Block Capitals):

Position:

on Behalf of (Company Name in Block Capitals as specified in Applicant Details of this application form)

confirm that all necessary landowner consents are in place for the substation at the coordinates as specified in Site Details of this application form and the generation site.

Signed: \_\_\_\_\_ Date:

and witnessed by Solicitor (Name in Block Capitals)

Signed: \_\_\_\_\_ Date:

Solicitors Address

**Please note the application will be returned to the applicant if submitted without a solicitors stamp.**

Solicitors stamp:

### 24. SIGNATURE OF APPLICANTS:

I/We accept ESB Networks DAC General Conditions relating to the connection and all amendments, which ESB Networks DAC may make from time to time. I/We agree to grant ESB Networks DAC all necessary access to bring the network to the premises. I/We acknowledge that ESB Networks DAC shall be entitled to connect other customers to the network.

**Signature of Applicant:** \_\_\_\_\_ **Date:**

If signing on behalf of a Partnership, Limited Company, or other Legal Entity, or as a duly Authorised Agent.

**Full Name in Block Capitals:**

**Capacity:**

[ESB Networks DAC may require the signatory to produce evidence of authority to bind the applicant by his/her signature].

**Signature of Witness:** \_\_\_\_\_ **Date:**

**Address of Witness:**

Note: ESB Networks DAC reserves the right to request additional data if necessary and the applicant agrees to provide such information promptly. The connecting party will be required at the relevant time to comply with Connection Agreement and the Distribution Code and provide information in accordance with these documents. ESB Networks DAC regrets it cannot accept responsibility for delays or mistakes if this application is completed incorrectly. If this application is incomplete the form will be returned to you.