



Draft

Standard Prices for Generator Connections 2020

Revision Date: 25 08 2020

Issued by: ESB NETWORKS DAC

Document Number: DOC-050110-AXU

Revision: 11

Approved by: [CRU] Draft

Effective Date: TBC

**Regulation and Commercial
Network Assets
ESB Networks DAC
Distribution System Operator**

CONTENTS

| | |
|---|----|
| 1.0 introduction | 3 |
| 2.0 Standard Pricing Approach | 3 |
| 2.1 Standard Pricing Process..... | 4 |
| 2.2 Pass through Costs | 4 |
| 2.3 Proposed Amendments to Current Charges..... | 6 |
| SCHEDULE 1: CHARGES FOR GENERATORS EXCL VAT..... | 7 |
| Schedule 1a: Line Standard Charges..... | 10 |
| Schedule 1b: Cable Standard Charges | 12 |
| Schedule 1c: 110 kV Station Standard Charges | 14 |
| Schedule 1d: 38kV Station Standard Charges..... | 21 |
| Schedule 1e: Miscellaneous Station Standard Charges..... | 29 |
| Schedule 1f: Metering Standard Charges | 35 |
| Schedule 1g: Communications & Protection Standard Charges..... | 36 |
| Schedule 1h: 38 kV Customer Compound [At Generator Site] Standard Charges | 37 |

1.0 INTRODUCTION

A key principle of the Group Processing Approach (and non-Group Processing Approach) for the DSO connections and the provision of connection offers in a timely manner is the implementation of the Standard Pricing approach. Under this approach a standard price for the main items on which such connection offers were based was approved by the then Commission for Energy Regulation in its Decision paper, Standard Pricing Approach for Connecting Renewable Generators to the Distribution Networks (CER/05/090). These standard prices were based on 2007 costs.

The DSO subsequently agreed with the CRU that these charges should be updated on an annual basis, this was initially based on forecast CPI and in 2010 it was agreed that they should be updated based on forecast HICP from 2011 onwards. In addition, DSO has revised the charges to reflect any over or underestimates in forecasts for CPI and HICP estimates used in the previous year's costs. The Commission has approved these updated standard charges under Section 36 of the Electricity Regulation Act, 1999.

While in recent years the charges were indexed, a full review of the charges has not taken place since 2007. The DSO has undertaken to complete a full review of the charges, based on the most up-to-date information available, experience of actual costs in relation to the procurement of equipment and undertaking connection works along with reviewing the scope of works included within the Standard Charges. During the review, the DSO identified a number of charges which are not in use and proposes to discontinue these. As part of the review of the Standard Charges, many of the charges now include an SLD in addition to identifying what is included and excluded from the scope. In general, civil costs are not included in the Standard Charges and will be charged on a pass through basis as per section 2.2 below.

It is intended going forward that DSO will submit revised charges each year to the CRU for their consideration and approval.

2.0 STANDARD PRICING APPROACH

The application of the standard pricing approach, as outlined below, is the most effective and equitable means of processing the applications while facilitating the provision of DSO connection offers in a timely manner. For avoidance of doubt, this approach applies to both the shared and dedicated connection assets for generators. The standard pricing process and charges are outlined below.

2.1 STANDARD PRICING PROCESS

1. The DSO connection offer pricing is based upon a desktop study to estimate the volume and type of material required. The DSO reserves the right to adjust the connection offer if a more detailed study results in a different cost estimate.
2. The proposed connection is then costed using the schedule of charges detailed in Schedule 1.
3. Following acceptance of the connection offer, design of the project commences and planning permission and consents are obtained.
4. Costs identified as pass-through (see section 2.2) in the connection offer will be estimated as early as possible in the process. Over the course of the project, as the extent of these costs become clearer the estimates shall be revised. The final charge for pass through costs is given post energisation so that their costs can be included in the final payment.

All pass through cost included in the customer's offer are based on the information available at the time of offer study. Following scoping and detailed design and construction, these pass through costs shall be further defined and communicated to the customer via their stage payment invoices.

2.2 PASS THROUGH COSTS

The Generator is advised that certain costs are pass-through ("Pass Through Costs") from the System Operator to the Generator who will be responsible for their payment in full. These costs are a non-exhaustive exclusion from the Standard Charge. The majority of these costs will be determined at the scoping, detailed design and construction phases of the System Operator's Connection Works and will be advised to the Generator at these points. However, where feasible, an estimate of these costs, or information which may allow the Generator estimate the costs, may be provided at offer stage on the basis that such estimates or information are not an obligation by the System Operator to commit to these estimates or information.

The following are a non-exhaustive list of Pass Through Costs i.e. costs that are excluded in the Standard Charges contained in this paper but which may be charged to the Generator:

- Civil Works:
 - All civils costs have been excluded from the proposed 2020 GSC's, with the exception of charges relating to OHL works (GSC 5,7 & 12) where the costs of pole / mast foundations have been included as they are inherent in the pole / mast installation works in these charges. Note: 4 GSC's (13,14, 24 & 34) are identified as civils only for refund or estimating purposes, and these costs are purely civils in nature.
- Civil design fees, supervision and all other associated costs;

- Site purchase and associated costs, charges and fees;
- Planning Fees including all associated costs, charges and fees which are necessary to complete the application and comply with all statutory or other requirements;
- Compliance with all Planning Permission conditions.
- Temporary generation and/or any temporary equipment such as a temporary transformers, mobile bays and any associated works/costs if required to facilitate the Generator's connection;
- Working outside normal working hours where deemed necessary to facilitate the customer's connection works
- Any pass-through costs advised by the TSO;
- Cable testing
- Security – cost of security which is required e.g. at stations to prevent material theft.
- Site enabling works – preparatory works required in advance of the Generator's connection works, such as, but not limited to relocation of existing services e.g. overhead or underground services, and/or demolition works, removal of contaminated material etc.,
- Land damage payments made to landowners due to ESB Networks accessing property;
- Land compensation;
- Additional costs associated with access to the works, and transporting materials and labour to same due to abnormal ground or site conditions, environmental constraints and the like;
- Abnormal ground or site conditions in regard to, but not limited to: rock, peat, surface and or ground water; bridge, river crossings, forestry etc;
- Outage constraints;
- Legal costs associated with asset transfer
- Wayleaves and Consents compensation
- The costs associated with forestry compensation;
- Lock out costs - where DSO staff and/or their contractors are prevented from accessing a site where customer's connection works are due to be undertaken;

2.3 PROPOSED AMENDMENTS TO CURRENT CHARGES

- Previous list of 54 GSC's, is now reduced to 39 for consideration as part of this submission. Selection has been based on the following:
 - Inclusion of all 32 GSC's that were used in any of the 95 ECP-1 offers issued to date. These have been reviewed and updated as part of this submission.
 - Inclusion of the Civils Estimate charges (ref 13,14, 24 & 34) which are for refund or estimating purposes only.
 - Inclusion of one other charge which analysis indicates is likely to be needed in future offers. This has also been reviewed and updated for this submission.
 - Splitting of charge 9 into charges 9 and 9a to allow for more accurate charging in future offers. Charge 9a (Installation of ASC (Arc Suppression Coil) on 38/110kV Cable) was previously included in the standard per km cable charge but it is deemed more appropriate to remove it from that charge and identify it separately so that it is only applied in offers where specifically required.
 - Addition of one new charge for 110kV NVD (Installed on both Transformers) (reference 55) which occurred in multiple ECP-1 offers as a non-standard charge.

GSC's which are not outlined above will not be maintained as standard charges and are noted as "Discontinued" in summary tables GSC's for information purposes.

SCHEDULE 1: CHARGES FOR GENERATORS EXCL VAT

| Standard Charges Summary | | |
|--------------------------|--|-----------------|
| Ref | Description | Standard Charge |
| 1 | 110 kV SC Woodpole 300 mm ² ACSR 80°C | Discontinued |
| 2 | 110 kV SC Woodpole 430 mm ² ACSR (< 10 km) 80°C (New Build only) | Discontinued |
| 3 | 110 kV SC Woodpole 430 mm ² ACSR (> 10 km) 80°C (New Build only) | Discontinued |
| 4 | 38 kV SC Woodpole 300 mm ² ACSR 60°C | Discontinued |
| 5 | 38 kV SC Woodpole 150 mm ² AAAC 80°C | €98,470 |
| 6 | 38 kV SC Woodpole 100 mm ² ACSR 60°C | Discontinued |
| 7 | MV SC Woodpole 150 mm ² AAAC / 92 mm ² SCA 65°C | €51,820 |
| 8 | 110 kV – 630 mm ² XLPE (AL) Single Circuit | €379,130 |
| 9 | 38 kV – 630 mm ² XLPE (AL) Single Circuit | €105,310 |
| 9a | 38kV Arc Suppression Coil (ASC 200A); on 38kV Cable lengths > 1km <i>New ASC charge proposed – previously included in per km charge above</i> | €347,360 |
| 10 | MV – 400 mm ² XLPE (AL) Single Circuit | €39,020 |
| 11 | 38 kV Cable End Mast | Discontinued |
| 12 | 110 kV Cable End Mast | €247,010 |
| 13 | 110 kV and 38 kV Cable Civils (for refund or estimating purposes only) | €379,210 |
| 14 | MV Cable Civils (for refund or estimating purposes only) | €210,850 |
| 15 | New 110 kV AIS “H-Type” Single Busbar Outdoor Station (Strung Busbar) | Discontinued |
| 16 | New Tail-fed (Single Supply) Outdoor AIS 110 kV Station (Strung Busbar) | Discontinued |
| 17 | New 110 kV/MV Station (excluding Site Purchase & Civil Works) | Discontinued |
| 18 | 110 kV/38 kV 63 MVA Green Field Transformer Package | € 1,737,450 |
| 19 | 110 kV/38 kV 31.5 MVA Green Field Transformer Package | € 1,430,600 |
| 20 | 110 kV/MV 20 MVA Green Field Transformer Package | € 1,143,630 |
| 21 | 110 kV/MV 31.5MVA Green Field Transformer Package | €1,315,500 |
| 22 | Uprate 1*31.5 MVA to 2*31.5 MVA Substation | Discontinued |
| 23 | Uprate 2*31.5 MVA to 2*63 MVA Substation | €3,678,490 |
| 24 | Civil works for a Typical Outdoor 110 kV Station Based on the layout of Item 15 (for refund or estimating purposes only) | €1,531,120 |

| Standard Charges Summary (continued) | | |
|--------------------------------------|---|-----------------|
| Ref | Description | Standard Charge |
| 25 | New 2*5 MVA Station | Discontinued |
| 26 | 5 MVA 38 kV/MV Green Field Transformer Package | €809,740 |
| 27 | 10 MVA 38 kV/MV Green Field Transformer Package | Discontinued |
| 28 | 15 MVA 38 kV/MV Green Field Transformer Package | €1,017,430 |
| 29 | Install 5 MVA 38 kV/MV Transformer into Existing Station with 38 kV Busbar Extension | €848,460 |
| 30 | Install 10 MVA 38 kV/MV Transformer into Existing Station with 38 kV Busbar Extension | €929,860 |
| 31 | Install 5 MVA 38 kV/MV Transformer into Existing Station without 38 kV Busbar Extension | €786,280 |
| 32 | Install 10 MVA 38 kV/MV Transformer into Existing Station without 38 kV Busbar Extension | €867,680 |
| 33 | Upgrade 2*5 MVA Station to 2*10 MVA | Discontinued |
| 34 | Civil Works for a Typical Outdoor 38 kV Station (for refund or estimating purposes only) | €904,160 |
| 35 | New 110 kV AIS Line bay in existing 110 kV Single Busbar Outdoor Station | €726,080 |
| 36 | 38 kV Cubicle in 38 kV Station | €267,670 |
| 37 | 38 kV Cubicle in 110 kV Station | €309,290 |
| 38 | MV Cubicle in 110 kV or 38 kV Station | €212,900 |
| 39 | MV Cubicle with Interface Transformer | Discontinued |
| 40 | Half MV busbar | Discontinued |
| 55 | Installation of 110kV NVD (Neutral Voltage Displacement) Protection (on both Transformers) <i>New GSC proposed to due to frequent occurrence as non -standard charge</i> | €192,820 |
| 41 | 38 kV Meter and Power Quality | €55,930 |
| 42 | MV Metering and Power Quality < 10 MVA | €27,090 |
| 43 | MV Metering and Power Quality < 10 MVA (where MV CB is being charged as part of EGIP installation, no need for KKK) | €20,770 |
| 44 | MV Metering and Power Quality >= 10 MVA | €28,760 |
| 45 | MV Metering and Power Quality >= 10 MVA (where MV CB is being charged as part of EGIP installation, no need for KKK) | Discontinued |

| Standard Charges Summary (continued) | | |
|---|--|------------------------|
| Ref | Description | Standard Charge |
| 46 | Protection Implementation for MV Connections with MEC < 2 MW | €41,220 |
| 47 | SCADA & Communications Implementation for MV Connections with MEC >=2MW | €60,150 |
| 48 | SCADA Implementation for 38 kV Connections between 2 MW and 5 MW (and MV connections >= 2 MW and < 5 MW where there is no GPRS Coverage) | Discontinued |
| 49 | Protection & Switchgear for Standard MV Connection (G10 type Connection) | €53,520 |
| 50 | Embedded Generation Interface Protection (EGIP) for an MV Connection | €218,210 |
| 51 | Embedded Generation Interface Protection (EGIP) for a 38 kV Connection | €86,530 |
| 52 | Embedded Generation Interface Protection (EGIP) for a 110 kV Connection | €93,820 |
| 53 | ESB Networks Compound with Over-the-Fence Connection to Developer – Overhead Connection | €558,780 |
| 54 | ESB Networks Compound with Over-the-Fence Connection to Developer – Underground Connection | €595,600 |

SCHEDULE 1A: LINE STANDARD CHARGES

| Standard Charges - Lines Summary | | |
|----------------------------------|---|-----------------|
| Ref | Description | Standard Charge |
| 5 | 38 kV SC Woodpole 150 mm ² AAAC 80°C | €98,470 |
| 7 | MV SC Woodpole 150 mm ² AAAC / 92 mm ² SCA 65°C | €51,820 |

OVERARCHING ASSUMPTIONS

1. GENERAL

Line charges assume a typical ratio of poles/pole sets to masts. This ratio may significantly change depending on the routing.

Prices apply on a per km basis.

Charges do not include:

- Wayleave management flexibility payments (Access)
- Purchase of easements
- Shield wire
- High security lines

2. FOUNDATIONS

Foundations are included with all poles and masts.

3. OVERHEAD LINE RATINGS

- a. Higher rating assumes ambient temperature of 5°C; lower rating assumes ambient temperature of 25°C
- b. 250 kV BIL and Power Withstand of 95 kV correspond to the 52 kV IEC Voltage Class
- c. The system neutral is connected to earth through Peterson coils located at 110 kV/38 kV stations. On the occasion of a fault to the earth on one phase of the system, the voltage to earth on the healthy phases may exceed line voltage and this condition may be sustained for a considerable time (> 3 hours)

| Individual Design Assumptions (continued) | | |
|---|--|--|
| Ref | Description | Design Assumptions |
| 5 | 38 kV SC Woodpole 150 mm ² AAAC 80°C | Max design voltage: 41.5 kV BIL: 250 kV Power frequency withstand voltage: 95 kV Load rating: 511 A to 604 A Fault current rating: 12 kA for 1 second Design wind speed: 36 m/s on bare conductor; 16 m/s on conductor with 2.5 cm radial ice; Minimum creepage: 960 mm on glass insulators; 1280 mm on polymeric insulators Poles: 10.0/km Mast: 0.0/km Earth Wire: No |
| 7 | MV SC Woodpole 150 mm ² AAAC / 92 mm ² SCA 65°C | Max design voltage: 21.5 kV BIL: 125 kV Power frequency withstand voltage: 50 kV Load rating: 412 A to 516 A Fault current rating: 11.5 kA for 1 second Design wind speed: 645 m/s on bare conductor; 16 m/s on conductor with 2.5 cm radial ice; Minimum creepage: 900 mm Poles: 11.0/km Mast: 0.0/km Earth Wire: No |

SCHEDULE 1B: CABLE STANDARD CHARGES

| Standard Charges - Cables Summary | | |
|-----------------------------------|---|-----------------|
| Ref | Description | Standard Charge |
| 8 | 110 kV – 630 mm ² XLPE (AL) Single Circuit | €379,130 |
| 9 | 38 kV – 630 mm ² XLPE (AL) Single Circuit | €105,310 |
| 9a | 38kV Arc Suppression Coil (ASC 200A); on 38kV Cable lengths > 1km (New GSC, previously included in above per kM 38kV Charge) | €347,360 |
| 10 | MV – 400 mm ² XLPE (AL) Single Circuit | €39,020 |
| 12 | 110 kV Cable End Mast | €247,010 |
| 13 | 110 kV and 38 kV Cable Civils (for refund or estimating purposes only) | €379,210 |
| 14 | MV Cable Civils (for refund or estimating purposes only) | €210,850 |

OVERARCHING ASSUMPTIONS

1. GENERAL

Price for item 8 is for 1 km only. If more than 1 km of 110 kV cable is required, DSO will go to tender for the specific job and charge on a pass through basis.

Prices for items 9, 10, 13 & 14 apply on a per km basis.

2. CIVIL WORKS

Foundations are included with all Cable End Masts.

All other civil works, excavation and ducting are carried out by the generator in accordance with ESB Networks specifications.

Items 13 and 14 are assumed to be Roadway Day and are for refund or estimate purposes only.

| Individual Design Assumptions | | |
|-------------------------------|---|--|
| Ref | Description | Design Assumptions |
| 8 | 110 kV – 630 mm ² XLPE (AL) Single Circuit | Max design voltage: 123 kV BIL: 550 kV Power frequency withstand voltage: 230 kV Load rating: 600 A Fault current rating: 26 kA for 1 second |
| 9 | 38 kV – 630 mm ² XLPE (AL) Single Circuit | Max design voltage: 52 kV BIL: 250 kV Power frequency withstand voltage: 95 kV Load rating: 660 A Fault current rating: 20 kA for 1 second Includes cost of fibre optic cable Excludes ASC (see Charge 9a) |

| | | |
|----|---|--|
| 9a | 38kV Arc Suppression Coil (ASC 200A); on 38kV Cable lengths > 1km | 38 kV; 200A ASC installed in an existing substation ASC installed on plinth in an oil-tight bund Connection to the power transformer via mixture of underground cable and overhead conductor Based on standard layout, elevation and electrical schematic drawings |
| 10 | MV – 400 mm ² XLPE (AL) Single Circuit | Max design voltage: 22 kV BIL: 125 kV Power frequency withstand voltage: 50 kV Load rating: 500 A Fault current rating: 20 kA for 1 second |

DRAFT

SCHEDULE 1C: 110 KV STATION STANDARD CHARGES

| Standard Charges – 110 kV Stations Summary | | |
|--|---|-----------------|
| Ref | Description | Standard Charge |
| 18 | 110 kV/38 kV 63 MVA Green Field Transformer Package | € 1,737,450 |
| 19 | 110 kV/38 kV 31.5 MVA Green Field Transformer Package | € 1,430,600 |
| 20 | 110 kV/MV 20 MVA Green Field Transformer Package | € 1,143,630 |
| 21 | 110 kV/MV 31.5 MVA Green Field Transformer Package | €1,315,500 |
| 23 | Uprate 2*31.5 MVA to 2*63 MVA Station | €3,678,490 |
| 24 | Civil works for a Typical Outdoor 110 kV Station Based on the layout of Item 15 (for refund or estimating purposes only) | €1,531,120 |

OVERARCHING ASSUMPTIONS

1. GENERAL

All electrical connections are assumed to be standard.

Where a charge involves installation of equipment in an existing station, it is assumed that:

- adequate space is available both electrically and physically,
- common services including protection and earth grids are adequate,
- busbar protection is in place and adequate to cover new bays,
- remote end works are not included,
- current standard contracts for switchgear can be drawn down i.e. the existing station does not require the procurement of non-standard switchgear to facilitate installation in the existing space,

except where these items are specifically mentioned as allowed for in the charge.

2. CIVIL WORKS

No civil works are allowed for in charges 15 - 23.

18. 110 kV/38 kV 63 MVA Green Field Transformer Package

Standard Charge

€1,737,450

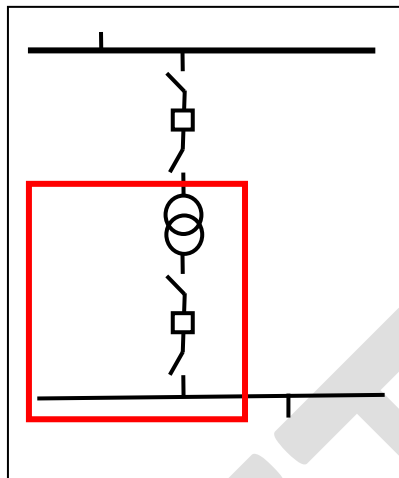

Electrical Assets [Including Design and Commissioning]

(1 off) 38 kV Transformer Bay, (1 off) 63 MVA 110/38 kV Transformer and 38 kV Single Busbar 2-bay extension including:

Disconnects + Steelwork

CTs + Steelwork

Control Cabling (Various)

Circuit Breakers

C&P Relays & Panel

Surge Arrestors + Steelwork

Transformer

CT & VT C&P Marshalling Boxes

Busbar + Steelwork

Neutral Treatment

Assumptions: Outdoor station.

19. 110 kV/38 kV 31.5 MVA Green Field Transformer Package

Standard Charge

€1,430,600

Electrical Assets [Including Design and Commissioning]

(1 off) 38 kV Transformer Bay, (1 off) 31.5 MVA 110/38 kV Transformer and 38 kV Single Busbar 2-bay extension including:

Disconnects + Steelwork

CTs + Steelwork

Control Cabling (Various)

Circuit Breakers

C&P Relays & Panel

Surge Arrestors + Steelwork

Transformer

CT & VT C&P Marshalling Boxes

Busbar + Steelwork

Neutral Treatment

Assumptions: Outdoor station.

DRAFT

20. 110 kV/MV 20 MVA Green Field Transformer Package
Standard Charge €1,143,630

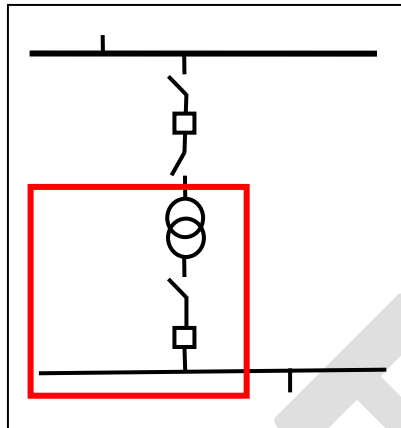

Electrical Assets [Including Design and Commissioning]

(1 off) MV Transformer Bay, (1 off) 20 MVA 110/MV Transformer and MV Busbar extension including:

| | | |
|-------------------|-------------------------------|-----------------------------|
| Disconnects | CTs & VTs | Surge Arrestors + Steelwork |
| Circuit Breaker | C&P Relays & Panel | Conductor |
| Transformer | CT & VT C&P Marshalling Boxes | Busbar + Steelwork |
| Neutral Treatment | Control Cabling (Various) | |

Assumptions: MV busbar is indoor.

21. 110 kV/MV 31.5 MVA Green Field Transformer Package
Standard Charge €1,315,500

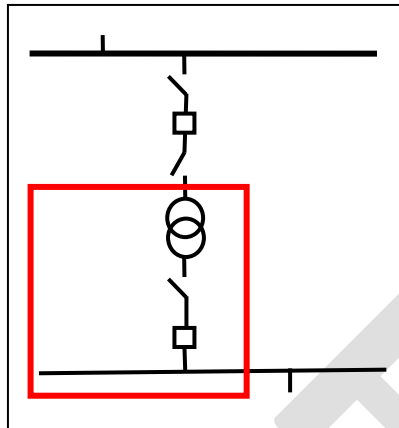

Electrical Assets [Including Design and Commissioning]

(1 off) MV Transformer Bay, (1 off) 31.5 MVA 110/MV Transformer and MV Busbar extension including:

| | | |
|-------------------|-------------------------------|-----------------------------|
| Disconnects | CTs & VTs | Surge Arrestors + Steelwork |
| Circuit Breaker | C&P Relays & Panel | Conductor |
| Transformer | CT & VT C&P Marshalling Boxes | Busbar + Steelwork |
| Neutral Treatment | Control Cabling (Various) | |

Assumptions: MV busbar is indoor.

23. Uprate 2*31.5 MVA to 2*63 MVA Substation

Standard Charge

€3,678,490

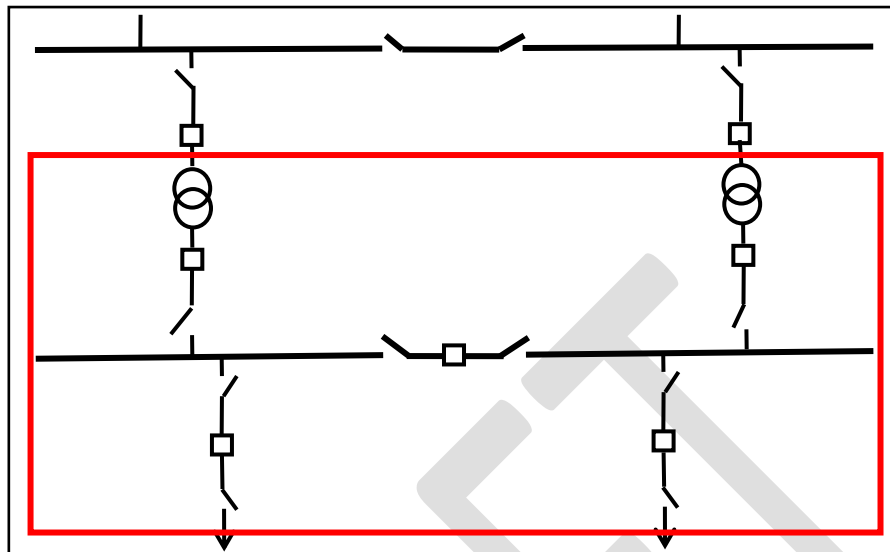

Electrical Assets [Including Design and Commissioning]

(2 off) 63 MVA 110/38 kV Transformers, (2 off) 38 kV Transformer Bays, (2 off) 38 kV Line Bays, (1 off) 38 kV Sectionaliser Bay and uprated 38 kV Busbar including:

| | | |
|-------------------------|-------------------------------|---------------------------|
| Transformers | CTs & VTs + Steelwork | Impedance Protection |
| Bund Pumps | CT & VT C&P Marshalling Boxes | Control Cabling (Various) |
| Disconnects + Steelwork | Insulator Posts + Steelwork | Conductors & Headgear |
| Circuit Breakers | Surge Arrestors + Steelwork | |

(2 off) 110 kV Transformer Bays Protection Upgrading:

| | | |
|-------------------------------------|------------------------|---------------------------|
| Transformer Differential Protection | Impedance Protection | Control Cabling (Various) |
| | Overcurrent Protection | C&P Marshalling Boxes |

Telecoms: Non-SCS

Assumptions: Lightning protection system not included.

BSM metering included.

No change required to ASC or to 38 kV busbar gantries and foundations.

38 kV bays are pedestal mounted AIS.

No change required to 110 kV neutral treatment.

Existing 38 kV protection to be retained.

Retirement of all upgraded equipment except the transformers is included.

24. Civil Works for a Typical Outdoor 110 kV Station

Indicative Civils Costs for Refund or Estimate Purposes Only

€1,531,120

Assumptions: This charge is based on the station design in charge 15.

DRAFT

SCHEDULE 1D: 38KV STATION STANDARD CHARGES

| Standard Charges – 38 kV Stations Summary | | |
|---|--|-----------------|
| Ref | Description | Standard Charge |
| 26 | 5 MVA 38 kV/MV Green Field Transformer Package | €809,740 |
| 28 | 15 MVA 38 kV/MV Green Field Transformer Package | €1,017,430 |
| 29 | Install 5 MVA 38 kV/MV Transformer into Existing Station with 38 kV Busbar Extension | €848,460 |
| 30 | Install 10 MVA 38 kV/MV Transformer into Existing Station with 38 kV Busbar Extension | €929,860 |
| 31 | Install 5 MVA 38 kV/MV Transformer into Existing Station without 38 kV Busbar Extension | €786,280 |
| 32 | Install 10 MVA 38 kV/MV Transformer into Existing Station without 38 kV Busbar Extension | €867,680 |
| 34 | Civil Works for a Typical Outdoor 38 kV Station (for refund or estimating purposes only) | €904,160 |

OVERARCHING ASSUMPTIONS

1. GENERAL

All electrical connections are assumed to be standard.

Where a charge involves installation of equipment in an existing station, it is assumed that:

- adequate space is available both electrically and physically,
- common services including protection and earth grids are adequate,
- busbar protection is in place and adequate to cover new bays,
- remote end works are not included,
- current standard contracts for switchgear can be drawn down i.e. the existing station does not require the procurement of non-standard switchgear to facilitate installation in the existing space,

except where these items are specifically mentioned as allowed for in the charge.

2. CIVIL WORKS

No civil works are allowed for in charges 25 - 33.

26. 5 MVA 38 kV/MV Green Field Transformer Package

Standard Charge

€809,740

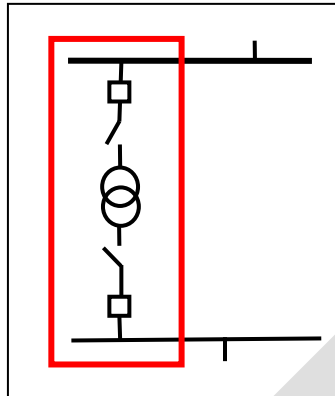

Electrical Assets [Including Design and Commissioning]

(1 off) 5 MVA Transformer, (1 off) 38 kV Transformer Bay including Busbar and (1 off) MV Transformer Bay including Busbar including:

| | | |
|-------------------|-------------------------------|------------------------------------|
| Transformer | CTs & VTs | Surge Arrestors |
| Neutral Treatment | CT & VT C&P Marshalling Boxes | Transformer Bay Busbar + Steelwork |
| Bund Pump | Control Cabling (Various) | Conductor |
| Disconnects | C&P Relays & Panel | |
| Circuit Breakers | | |
| Telecoms: | SCS | |

Assumptions: Installation in a new 110 kV or 38 kV station. MV Busbar is indoor.

28. 15 MVA 38 kV/MV Green Field Transformer Package

Standard Charge

€1,017,430

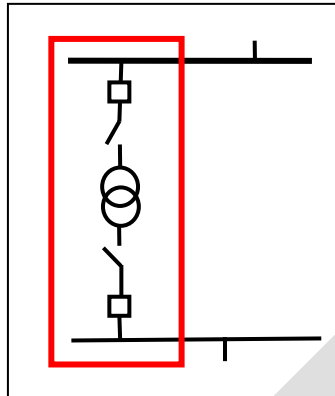

Electrical Assets [Including Design and Commissioning]

(1 off) 15 MVA Transformer, (1 off) 38 kV Transformer Bay including Busbar and (1 off) MV Transformer Bay including Busbar including:

| | | |
|-------------------|-------------------------------|--------------------------|
| Transformer | CTs & VTs | Surge Arrestors |
| Neutral Treatment | CT & VT C&P Marshalling Boxes | Transformer Bay Busbar + |
| Bund Pump | Control Cabling (Various) | Steelwork |
| Disconnects | C&P Relays & Panel | Conductor |
| Circuit Breakers | | |
| Telecoms: | SCS | |

Assumptions: Installation in a new 110 kV or 38 kV station. MV Busbar is indoor.

29. Install 5 MVA 38 kV/MV Transformer into Existing Station with 38 kV Busbar Extension

Standard Charge

€848,460

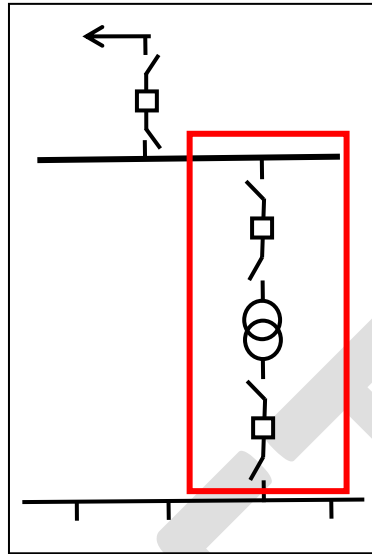

Electrical Assets [Including Design and Commissioning]

(1 off) 5 MVA 38 kV/MV Transformer, (1 off) 38 kV Transformer Bay, (1 off) MV Transformer Bay and 38 kV Busbar Extension including:

| | | |
|---------------------------|-------------------------------|--------------------------|
| Transformer | AIS Circuit Breakers | Earths |
| Neutral Treatment | CTs & VTs | Conductors |
| Bund Pump | Surge Arrestors | 38 kV & MV Bay Steelwork |
| Control Cabling (Various) | C&P Relays & Panels | 38 kV Busbar & Steelwork |
| Disconnects | CT & VT C&P Marshalling Boxes | |

30. Install 10 MVA 38 kV/MV Transformer into Existing Station with 38 kV Busbar Extension

Standard Charge

€929,860

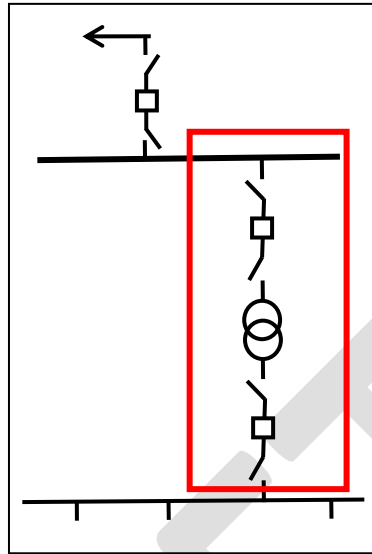

Electrical Assets [Including Design and Commissioning]

(1 off) 10 MVA 38 kV/MV Transformer, (1 off) 38 kV Transformer Bay, (1 off) MV Transformer Bay and 38 kV Busbar Extension including:

| | | |
|---------------------------|-------------------------------|--------------------------|
| Transformer | AIS Circuit Breakers | Earths |
| Neutral Treatment | CTs & VTs | Conductors |
| Bund Pump | Surge Arrestors | 38 kV & MV Bay Steelwork |
| Control Cabling (Various) | C&P Relays & Panels | 38 kV Busbar & Steelwork |
| Disconnects | CT & VT C&P Marshalling Boxes | |

31. Install 5 MVA 38 kV/MV Transformer into Existing Station without 38 kV Busbar Extension

Standard Charge

€786,280

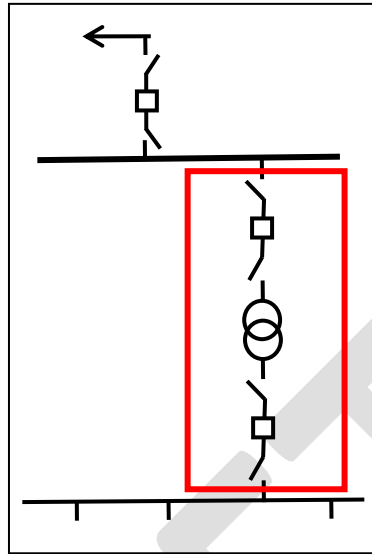

Electrical Assets [Including Design and Commissioning]

(1 off) 5 MVA 38 kV/MV Transformer, (1 off) 38 kV Transformer Bay and (1 off) MV Transformer Bay including:

| | | |
|---------------------------|-------------------------------|-------------------------|
| Transformer | AIS Circuit Breakers | Surge Arrestors |
| Neutral Treatment | CTs & VTs | Earths |
| Bund Pump | C&P Relays & Panels | Conductors |
| Control Cabling (Various) | CT & VT C&P Marshalling Boxes | 38kV & MV Bay Steelwork |
| Disconnects | | |

Assumptions: Spare 38 kV bay available with short cable run to transformer position.

32. Install 10 MVA 38 kV/MV Transformer into Existing Station without 38 kV Busbar Extension

Standard Charge

€867,680

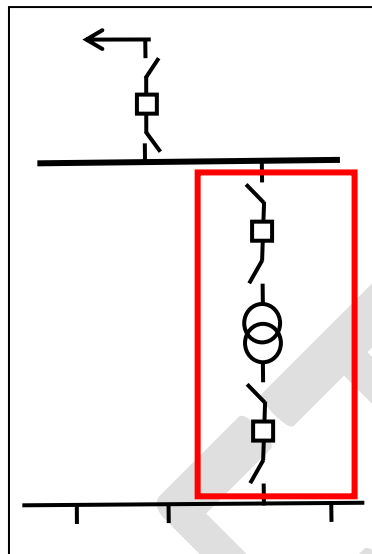

Electrical Assets [Including Design and Commissioning]

(1 off) 10 MVA 38 kV/MV Transformer, (1 off) 38 kV Transformer Bay and (1 off) MV Transformer Bay including:

| | | |
|---------------------------|-------------------------------|-------------------------|
| Transformer | AIS Circuit Breakers | Surge Arrestors |
| Neutral Treatment | CTs & VTs | Earths |
| Bund Pump | C&P Relays & Panels | Conductors |
| Control Cabling (Various) | CT & VT C&P Marshalling Boxes | 38kV & MV Bay Steelwork |
| Disconnects | | |

Assumptions: Spare 38kV bay available with short cable run to transformer position.

34. Civil Works for a Typical Outdoor 38kV Station

Indicative Civils Costs for Refund or Estimate Purposes Only

€904,160

Assumptions: This charge is based on the station design in charge 25.

DRAFT

SCHEDULE 1E: MISCELLANEOUS STATION STANDARD CHARGES

| Standard Charges – Miscellaneous Stations Summary | | |
|---|--|-----------------|
| Ref | Description | Standard Charge |
| 35 | New 110 kV AIS Line bay in existing 110 kV Single Busbar Outdoor Station | €726,080 |
| 36 | 38 kV Cubicle in 38 kV Station | €267,670 |
| 37 | 38 kV Cubicle in 110 kV Station | €309,290 |
| 38 | MV Cubicle in 110 kV or 38 kV station | €212,900 |
| 55 | Installation of 110kV NVD (Neutral Voltage Displacement) Protection (on both Transformers) | €192,820 |

OVERARCHING ASSUMPTIONS

1. GENERAL

All electrical connections are assumed to be standard.

Where a charge involves installation of equipment in an existing station, it is assumed that:

- adequate space is available both electrically and physically,
- common services including protection and earth grids are adequate,
- busbar protection is in place and adequate to cover new bays,
- remote end works are not included,
- current standard contracts for switchgear can be drawn down i.e. the existing station does not require the procurement of non-standard switchgear to facilitate installation in the existing space,

Except where these items are specifically mentioned as allowed for in the charge.

2. CIVIL WORKS

No civil works are allowed for in charges 35 – 38 & 55.

35. New 110 kV AIS Line Bay in Existing 110 kV Single Busbar Outdoor Station

Standard Charge

€726,080

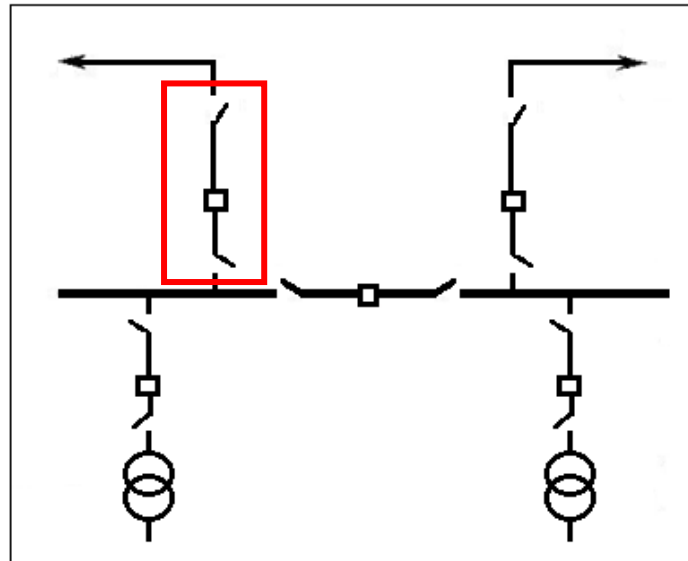

Electrical Assets [Including Design and Commissioning]

(1 off) 110 kV Line Bay including:

Disconnects + Steelwork

Surge Arrestors + Steelwork

CT & VT C&P Marshalling Boxes

Circuit Breaker

Insulator Posts + Steelwork

C&P Relays & Panel

CTs & VTs + Steelwork

Control Cabling (Various)

Conductor

Telecoms: SCS /RTU connection works

Assumptions: Strung/tubular busbar.

36. 38 kV Cubicle in 38 kV Station

Standard Charge

€267,670

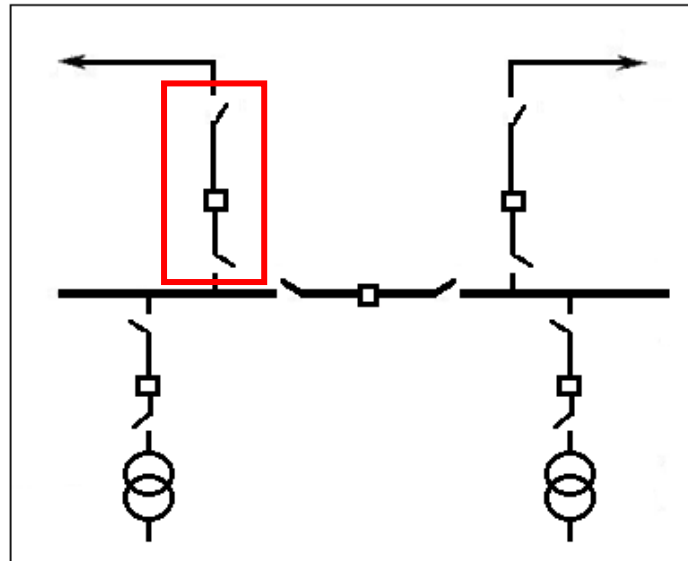

Electrical Assets [Including Design and Commissioning]

(1 off) 38 kV Cubicle including:

- | | | |
|---------------------|-------------------------------|------------------------|
| Disconnects | Control Cabling (Various) | Conductor |
| AIS Circuit Breaker | CT & VT C&P Marshalling Boxes | Bay Busbar & Steelwork |
| CTs & VTs | C&P Relays & Panel | |

Telecoms: SCS /RTU connection works

Assumptions: Outdoor ground mounted cubicle;
Spare 38kV bay available;
Max design voltage 52kV;
BIL 250kV;
Power frequency withstand voltage of 95kV;
Busbar load rating 1000-1250A;
Busbar fault rating 20kA for 1 second.

37. 38 kV Cubicle in 110 kV Station

Standard Charge

€309,290

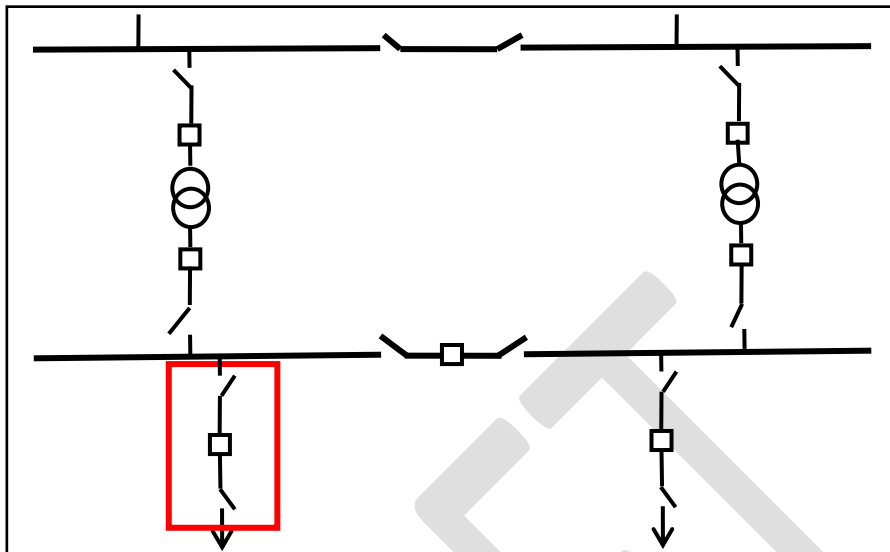

Electrical Assets [Including Design and Commissioning]

(1 off) 38 kV Cubicle including:

Disconnects

Control Cabling (Various)

C&P Relays & Panel

AIS Circuit Breaker

CT & VT C&P Marshalling Box

Conductor

CTs & VTs

Telecoms: SCS /RTU connection works

Assumptions: Outdoor ground mounted cubicle;
 Spare 38kV bay available;
 Max design voltage 52kV;
 BIL 250kV;
 Power frequency withstand voltage of 95kV;
 Busbar load rating 1000-1250A;
 Busbar fault rating 20kA for 1 second.

38. MV Cubicle in 110 kV or 38 kV Station

Standard Charge

€212,900

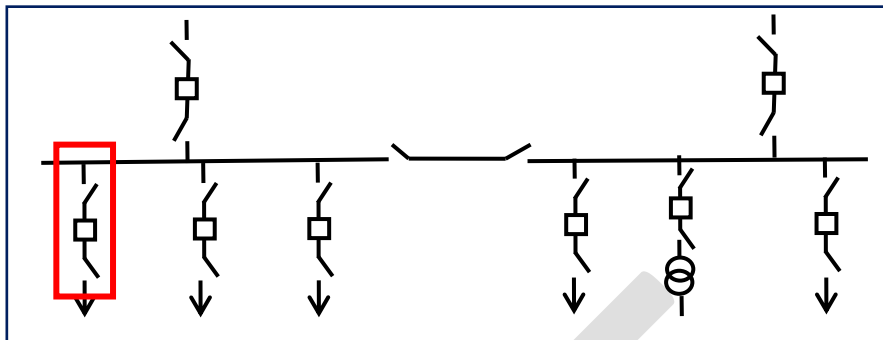

Electrical Assets [Including Design and Commissioning]

(1 off) MV Cubicle including:

AIS Circuit Breaker

CTs & VTs

Control Cabling (Various)

Disconnects

MV Busbar & Steelwork

C&P Relays & Panel

Telecoms: SCS

- Assumptions:** Existing MV busbar available;
 Spare bay available;
 Bay has all standard MV functionality;
 Max design voltage 24kV;
 BIL 125kV;
 Power frequency withstand voltage 50kV;
 Busbar load rating 2000A, fault rating 20kA for 1 second;
 Protection relays to include earth fault, overcurrent, directional sensitive earth fault.

| Individual Design Assumptions | | |
|-------------------------------|--|--|
| Ref | Description | Design Assumptions |
| 55 | Installation of 110kV NVD (Neutral Voltage Displacement) Protection (on both Transformers) | <p>110 kV Neutral VT installed on a base adjacent to power transformer in an existing substation</p> <p>Connection to the power transformer via overhead conductor</p> <p>NVD protection relay installed in a new cabinet</p> <p>Based on standard layout, elevation and electrical schematic drawings</p> |

DRAFT

SCHEDULE 1F: METERING STANDARD CHARGES

| Standard Charges – Metering Summary | | |
|-------------------------------------|---|-----------------|
| Ref | Description | Standard Charge |
| 41 | 38 kV Meter and Power Quality | €55,930 |
| 42 | MV Metering and Power Quality < 10 MVA | €27,090 |
| 43 | MV Metering and Power Quality < 10 MVA (where MV CB is being charged as part of EGIP installation, no need for KKK) | €20,770 |
| 44 | MV Metering and Power Quality >= 10 MVA | €28,760 |

ASSUMPTIONS

1. Metering costs are included in all charges (41-45).
These assume only one set of meters installed.
In the case of > 10 MVA (i.e. charges 41, 44 & 45) the set also includes check meters.
In the event that additional meter sets are required (e.g. for reasons of supplier contracts) then additional charges will apply.
2. CTs & VTs are included in all charges.
3. Power quality meters and transducers are included in all charges.
4. Charges 42 and 44 include KKK units. They assume EGIP not installed.

NOTE

The metering charges for Power Quality in items 41, 42, 43, 44, and 45 will change as the current Power Quality equipment is becoming obsolete and is subject to a tendering process. The revised charges will cover the costs for the new power quality metering technology, communication equipment, configuration and installation of communication equipment, and IT infrastructure and software licenses for the system management and data analysis. The annual Operation and Maintenance (O&M) charges will change to include the annual data communication costs for transmitting the power quality information from the power quality meters to the central database for data analysis.

Any Customer that pays their Second Stage Payment in 2019 will have the current Power Quality equipment installed and charged accordingly. Any Customer that pays its Second Stage Payment after 2019 may (at the discretion of ESB Networks) have the new Power Quality equipment installed and will be charged accordingly. These new rates will not be known until after the associated procurement process is complete.

SCHEDULE 1G: COMMUNICATIONS & PROTECTION STANDARD CHARGES

| Standard Charges – Communications & Protection Summary | | |
|--|---|-----------------|
| Ref | Description | Standard Charge |
| 46 | Protection Implementation for MV Connections with MEC < 2 MW | €41,220 |
| 47 | SCADA & Communications Implementation for MV Connections with MEC >= 2 MW | €60,150 |
| 49 | Protection & Switchgear for Standard MV Connection (G10 type) | €53,520 |
| 50 | Embedded Generation Interface Protection (EGIP) for an MV Connection | €218,210 |
| 51 | Embedded Generation Interface Protection (EGIP) for a 38 kV Connection | €86,530 |
| 52 | Embedded Generation Interface Protection (EGIP) for a 110 kV Connection | €93,820 |

ASSUMPTIONS

1. Embedded Generation Interface Protection (Charges 49-52) is designed to standard.
2. No civil works required.

| Individual Design Assumptions | | |
|-------------------------------|---|---|
| Ref | Description | Design Assumptions |
| 46 | Protection Implementation for MV Connections with MEC < 2 MW | Nulec recloser to be installed Recloser to be installed between the metering CT/VT and the customer MV tail cables. |
| 47 | SCADA and Protection Implementation for MV Connections with MEC >= 2 MW | Nulec recloser to be installed as part of charge #49 Remote control facilities for NULEC recloser required Recloser to be installed between the metering CT/VT and the customer MV tail cables. Includes Radio Polling Station |

SCHEDULE 1H: 38 KV CUSTOMER COMPOUND [AT GENERATOR SITE] STANDARD CHARGES

| Standard Charges – 38 kV Customer Compound [At Generator Site] Summary | | |
|---|--|------------------------|
| Ref | Description | Standard Charge |
| 53 | ESB Networks Compound with Over-the-Fence Connection to Developer – Overhead Connection | €558,780 |
| 54 | ESB Networks Compound with Over-the-Fence Connection to Developer – Underground Connection | €595,600 |

DRAFT

53. ESB Networks Compound with Over-the-Fence Connection to Developer – Overhead Connection

Standard Charge

€558,780

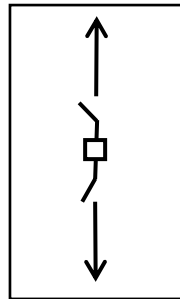

Electrical Assets [Including Design and Commissioning]

38 kV Compound Overhead to Overhead Connection including:

| | | |
|---------------------------|------------------------------|----------------|
| Busbar & Steelwork | C&P Relays & Marshalling Box | Metering |
| AIS Circuit Breaker | C&P Mimic & Signal Box | Battery System |
| VTs & CTs | Surge Arrestors | Conductor |
| Disconnects | Earth Grid | Mast |
| Control Cabling (Various) | CT/VT Metering | |

Telecoms: RTU.

Assumptions: Incomer is overhead;
 Outgoer to customer may be either overhead or cable;
 Compound fencing and stoning will be put in place and a control room will be provided by the Generator.

Includes EGIP Protection at 38kV & Customer Interface Kiosk

54. ESB Networks Compound with Over-the-Fence Connection to Developer –Underground Connection

Standard Charge

€595,600

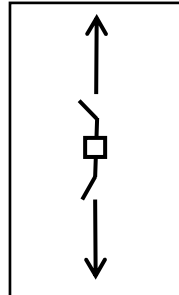

Electrical Assets [Including Design and Commissioning]

38 kV Compound Cable to Cable Connection including:

| | | |
|---------------------------|------------------------------|----------------|
| Busbar & Steelwork | C&P Relays & Marshalling Box | CT/VT Metering |
| AIS Circuit Breaker | C&P Mimic & Signal Box | Metering |
| VTs & CTs | Surge Arrestors | Battery System |
| Disconnects | Earth Grid | Cable |
| Control Cabling (Various) | | |

Telecoms: RTU.

Assumptions: Incomer is cable;
 Outgoer to customer may be either overhead or cable;
 Compound fencing and stoning will be put in place and a control room will be provided by the Generator.

Includes EGIP Protection at 38kV & Customer Interface Kiosk

Glossary

| Acronym | Full Name |
|----------------|---|
| AAAC | All Aluminium Alloy Conductor |
| AAP | Alarm Annunciation Panel |
| AC | Alternating Current |
| ACSR | Aluminium Conductor Steel Reinforced |
| AIS | Air Insulated Switchgear |
| ASC | Arc Suppression Coil |
| BIL | Breakdown Insulation Level |
| C&P | Control and Protection |
| CB | Circuit Breaker |
| CER | Commission for Energy Regulation |
| CPI | Consumer Price Index |
| CRU | Commission for Regulation of Utilities |
| CT | Current transformer |
| DC | Direct Current |
| DSO | Distribution System Operator |
| EGIP | Embedded Generation Interface Protection |
| ESBN | ESB Networks DAC |
| GIS | Gas Insulated Switchgear |
| GPRS | General Package Radio Service |
| HICP | Harmonised Indexation of Consumer Prices |
| IEC | International Electro-Technical Commission |
| KKK | Reference to a particular type of switch |
| kV | Kilo Volts |
| kVA | Kilo Volt-Amperes |
| LCTA | Least Cost Technically Acceptable |
| MEC | Maximum Export Capacity |
| MV | Medium Voltage |
| MVA | Mega Volt-Amperes |
| MW | Megawatts |
| NES | Neutral Earth Switch |
| NULEC | Brand name of a particular recloser device with built in protection |
| NVD | Neutral Voltage Displacement |
| RTU | Remote Terminal Unit |
| SC | Single Circuit |
| SCA | Steel Cored Aluminium |
| SCADA | Supervisory Control And Data Acquisition |
| SCS | Station Control System |
| SLD | Single Line Diagram |
| TSO | Transmission System Operator |
| VAT | Value Added Tax |
| VT | Voltage Transformer |
| XLPE (AL) | Cross-Linked Polyethylene (Aluminium) |